

STUDI E SAGGI LINGUISTICI

XLVII

RIVISTA FONDATA DA
TRISTANO BOLELLI

2009

Edizioni ETS
PISA

RISERVATO OGNI DIRITTO DI PROPRIETÀ
E DI TRADUZIONE

Studi e Saggi Linguistici

Registrazione Tribunale di Pisa 12/2007 in data 20 Marzo 2007

Periodicità annuale

Direttore responsabile: Alessandra Borghini

SOMMARIO

Romano Lazzeroni, <i>Causativi e transitivi indoeuropei: fra comparazione e tipologia</i>	7
Marco Mancini, <i>Il toponimo aramaico Gamlā' e il bilinguismo di Flavio Giuseppe</i>	25
Tobias Scheer, <i>External sandhi: what the initial CV is initial of</i>	43
Diana Passino, <i>The allomorphy of nən as a case of vowel/zero alternation in Teraman Abruzzese</i>	83
Roberta Melazzo, <i>Suffixes of Bahuvrihis in the Ṛg Veda</i>	111
Elisa Mattiello, <i>A morphopragmatic analysis of English and Italian negative prefixes</i>	125
Florida Nicolai - Silvia Maria Sottofattori, <i>The boomerang tic</i>	157
Emanuele Banfi - Giorgio Francesco Arcodia, <i>Conjunctive Markers in (Mandarin) Chinese and Indo-European Languages: an Interlinguistic Comparison</i>	169
 <i>Recensioni</i>	
Maurizio Bettini, <i>Voci. Antropologia sonora del mondo antico</i> (G. Marotta)	189
Giuseppe Gitti, <i>Sordità e apprendimento della lingua</i> (C. Taddei)	203
 <i>Abstracts</i>	
<i>Indirizzo degli Autori</i>	225
	231

TOBIAS SCHEER

External sandhi: what the initial CV is initial of*

1. *Introduction: a representational and a procedural sandhi-blocker*

Phonological processes usually apply across morpheme, but not across word boundaries¹. This is the situation that phonologists consider to be the default, and on which phonological theories are built. Cases where phonology applies across word boundaries attract specific attention: traditionally they are called (external) sandhi (or connected speech), and generative phonology has devised an entire theory in order to handle them: the subject matter of *Prosodic Phonology* (Selkirk, 1981 [1978], 1986, Nespor and Vogel, 1986 etc.) and of its instrument, the *Prosodic Hierarchy*, is to formalize the intervention of syntactic conditions (i.e. the relationship between words) in phonological matters.

Phonologists agree that external sandhi is a situation where all barriers between words have been removed and phonology “does not see” the morpho-syntactic boundary, just like it may or may not “see” morphological boundaries: while the boundary of class 1 affixes such as *-al* is invisible (*parént-al* is computed as a single stress domain and therefore receives regular penultimate stress), the boundary of class 2 affixes like *-hood* is taken into account by the stress assigning mechanism (the root is a stress domain by itself and receives penultimate stress: *párent-hood*). In other words, the default is that specific action is taken in order to prevent phonology from applying across word boundaries: barriers are established that provoke the anti-sandhi situation, i.e. when phonological processes are blocked by word boundaries. It is the exceptional absence of these barriers that produces the sandhi situation.

This article inquires on the exact nature of the barriers at hand. A priori there are two possible reasons for the phonological incommunication across words: one is procedural, the other representational. The latter is phonology-internal in the sense that the barrier is some phonological structure: a represen-

* This article is a piece of SCHEER (forthcoming a). I am indebted to Giovanna Marotta and Diana Passino for very helpful comments, and to Jean-Philippe Dalbera and Marie-Josée Dalbera-Stefanaggi for their patient and insightful introduction to the Corsican micro-cosmos.

¹ Here and below, “word” is shorthand for “some morpho-syntactically relevant chunk at about the word size”; it does not imply any take on what counts as a “word” in which language (clitics etc.).

tational unit that carries morpho-syntactic information and was inserted into the phonological representation inhibits cross-word communication. In SPE, a phonological process was blocked by the hash mark # if not otherwise specified in the rule. *Prosodic Phonology* has autosegmentalized hash marks by representing relevant morpho-syntactic information in terms of an autosegmental arboreal structure, the *Prosodic Hierarchy*. In this environment, processes do not apply across word boundaries because they are made sensitive to a condition that specifies their domain of application, for example “process X applies within the *Prosodic Word*”, and the *Prosodic Word* coincides with the morpho-syntactic word.

By contrast, the procedural reason for anti-sandhi behaviour is extra-phonological in the sense that phonological computation is blocked without any participation of phonology itself. Since Chomsky *et al.*, 1956: 75), morpho-syntax and phonology communicate through cyclic derivation, a mechanism that has known various implementations (as the *Transformational Cycle* in SPE, as the *Phonological Cycle* in Mascaró, 1976) and is called *derivation by phase* in current minimalist syntax, of which it is the spine (Chomsky, 2000, 2001 and following). The idea is that phonological (and semantic) interpretation follows morpho-syntactic structure from inside out, i.e. from the most to the least embedded item. A no look-back proviso that is called the *Phase Impenetrability Condition* (PIC) today² inhibits cross-phase communication: previously interpreted material is “frozen” and inaccessible for further computation. Therefore, if two words [[A] [B]] sit in different phases, both A and B will be interpreted by themselves and hence frozen by *Phase Impenetrability*. When phonology applies to the outer cycle [A B], the shape of A and B that was achieved on the previous cycle cannot be modified. This assures that a given phonological process applies word-internally, but not across words.

The typical division of labour that is practised in phonology since the early 80s is that a procedural solution (i.e. *Lexical Phonology*³) is applied to internal anti-sandhi (i.e. processes that cannot cross morpheme boundaries), while the representational tools of the *Prosodic Hierarchy* deal with external anti-sandhi (i.e. processes that cannot apply across word boundaries). This custom notwithstanding, the two kinds of sandhi-blockers may in principle compete⁴.

² The history and various incarnations of this device are further discussed in SCHEER (forthcoming a, b).

³ Today OTed versions thereof, i.e. *Stratal OT* (KIPARSKY, 2000, BERMUDEZ-OTERO, forthcoming) or *DOT* (RUBACH, 1997 and following). The same is true for *Prosodic Phonology*, which was carried over into the constraint-based environment. Nothing in the discussion below hinges on eventual differences between the original theories of the 80s and modern OTed versions thereof.

⁴ Voices that call the customary division of labour into question are very rare.

On very rare occasions they actually do in the literature: nasal assimilation in English for example was analyzed along both lines.

The nasal of *in- does*, but the nasal of *un- does not assimilate to a following stop: compare un-predictable with im-possible* (cf. *in-offensive*). The procedural solution is based on a contrasting cyclic structure (e.g. Kaye, 1995): [[un] [predictable]] vs. [in possible]. *Un- being spelt out in isolation*⁵, its nasal is frozen by the PIC and cannot assimilate to the following stop on the outer cycle. The competing representational solution builds on the contrasting definition of prosodic tree structure (phonological phrasing, Rubach and Booij, 1984, Rubach, 1984: 221 ff., Vogel, 1991): while *un- is a Prosodic Word (PrW)* in its own right, *in- is part of the PrW* of the root, i.e. [[un]_ω [predictable]_ω] vs. [in possible]_ω. Nasal assimilation then is specified for applying only within *PrWs*.

2. Representational communication with phonology

2.1. Diacritics and melody do not qualify as carriers of morpho-syntactic information

It was mentioned that the default assumption among phonologists is that the word boundary causes phonological incommunication: the *Prosodic Hierarchy* only enters the scene when phonology jumps over word boundaries (or below the word level in matters related to prefixes and compounds). Below I look at the distribution of the two types of sandhi-killers in greater detail and

Based on the fact that the area below the word level may in principle be covered by representational means (the *Prosodic Hierarchy*), while the area at and above the word level may not be handled with the tools of *Lexical Phonology*, SELKIRK (1984) and INKELAS (1990) argue that the latter are redundant and need to be done away with. The literature indeed draws an asymmetrical picture regarding phonological traces of cyclic spell-out: sequences of morphemes and sequences of words are sent to phonology in several chunks of growing size, but this piecemeal fire leaves only traces in the interpretation of the former. That is, there seem to be no cases where phonology records traces of the cyclic spell-out of words. This is encoded in the architecture of *Lexical Phonology*, where lexical phonology is, but post-lexical phonology is not cyclic. I call the absence of phonological traces of the cyclic spell-out of words the word-spell-out mystery (SCHEER, 2009, forthcoming a) because there is no reason why word sequences should not react on the same conditions that produce cyclic effects on morpheme sequences. Whether phonological effects of the spell-out of words are really absent from the record is an empirical question that deserves attention.

⁵ NEWELL and SCHEER (2007) discuss the syntactic aspects of this analysis (late insertion, a-cyclic merger).

from the perspective of a specific assumption regarding the representational device. Just like hash marks #, the *Prosodic Hierarchy* is a diacritic and therefore does not qualify for the representation of morpho-syntactic information in phonology. Like other modules, phonology understands only its own vocabulary, to which *Prosodic Words*, *Prosodic Phrases* etc. do not belong. Truly phonological vocabulary is the one that is used when phonological processes apply in absence of any extra-phonological conditioning (e.g. when a palatalization turns k into tʃ before front vowels). Unlike melodic primes (frontness, occlusion etc.) and bottom-up constructed units such as syllable structure and feet, items of the *Prosodic Hierarchy* are top-down constructions (they are unpredictable from lower units) and intervene only when morpho-syntactic information needs to be imported. They are therefore alien and just as diacritic as #s (Scheer, 2008, forthcoming a, more on this below).

On the other hand, melodic items are not possible carriers of morpho-syntactic information either: while the ultimate effect of morpho-syntactic bearing on phonology of course is always melodic, the question is whether there are cases where it is direct, i.e. not mediated by some structure (traditionally hash marks or prosodic constituency) at or above the skeleton.

Prima facie candidates for non-mediated influence are cases where a morpheme has no surface manifestation that could be identified in the linear string: it merely modifies material that belongs to other morphemes. *Umlaut*, or any floating morphemes in autosegmental terms for that matter, falls into this category. One may be tempted to conclude, then, that the boundary of the morpheme at hand materialises as the triggering melodic item in question. As far as I can see, however, such an analysis has never been proposed.

Let us take a closer look at *umlaut*. In German for example, *umlaut* may mark the plural of a noun, and in some cases nothing else carries the plural information: the plural marker appears only as a palatalising effect on the root vowel. Hence the plural of German *Mutter* [mʊtɐ] ‘mother’ is *Mütter* [mytɐ].

In the massive body of literature regarding this phenomenon, as far as I can see nobody has argued for an analysis whereby the plural boundary incarnates as a palatal agent, which then causes fronting of the back vowel. All phonological accounts hold that the lexical identity of the plural morpheme is a palatal piece of melody that is regularly linearised after the root. In linear SPE-type analyses, the morpheme identifies as an *-i* (its historical identity), which fronts the root vowel before being deleted by rule. In autosegmental environments, the lexical identity of the plural morpheme is a floating palatal prime, which parachutes on the root vowel and is never seen as such because it has no syllabic constituent that it can associate to. In any event, the lexicon is found to be the origin of the palatal element: no phonologist has thought of it in terms of the output of the translation of morpho-syntactic structure.

Another case are melodic items that appear at morpheme boundaries, but which do not belong to any morpheme themselves: in Italian for example *caffè* ‘coffee’ derives *caffè-tt-ino* ‘coffee-diminutive’ and *caffè-tt-iera* ‘coffee maker’ whereby a *tt* seems to mark the morpheme boundary (see Pagliano, 2003 for an analogous case of t-epenthesis in French). It is not true, however, that the *t* marks the suffix boundary, or the specific boundary associated to *-ino* and *-iera*: it is absent in *zuccher-iera* ‘sugar bowl’ for example. Here again, thus, the melodic effect appears to be mediated by (syllable) structure: it is not a melodic prime or a cluster of melodic primes that is inserted into the phonological string in place of a #; rather, the melodic effect – t epenthesis in our case – is parasitic on a structural unit that carries the morpho-syntactic information.

As far as I can see, if tacitly, the non-role of melody at the interface is undisputed: all phonological carriers of morpho-syntactic information in phonology that interface theories have used over the past 70 years are non-melodic (i.e. are inserted at or above the skeleton): juncture phonemes, SPE-type boundaries and the *Prosodic Hierarchy*. I therefore conclude in Scheer (2008, forthcoming a) that the only representational items that qualify as carriers of morpho-syntactic information in phonology are syllabic units: they are non-melodic and at the same time non-diacritic, that is truly phonological vocabulary.

2.2. Direct Interface

The idea is thus that only those units qualify as carriers of morpho-syntactic information that are used in phonological processes which are unconditioned by extra-phonological factors. Restricting the representational items that can be inserted into phonological representations as carriers of morpho-syntactic information in this way is the heart of *Direct Interface* (Scheer, 2008, forthcoming a). ‘Direct’ refers to the fact that all (diacritic) mediation between morpho-syntactic structure and phonological interpretation is done away with: there is no buffer such as hash marks or the *Prosodic Hierarchy* whose only function is to store morpho-syntactic information. Rather, morpho-syntactic information is directly translated into truly and active phonological vocabulary.

That diacritics do not qualify for the representation of morpho-syntactic information in phonology is fairly undisputed: it was a central argument against hash-marks in the early 80s (see Scheer, forthcoming a). The question, then, is to define what a diacritic is, and once this is done, what kind of object is left for a correct non-diacritic representation of morpho-syntactic information. Let us consider the following definition.

(1) definition of the term ‘diacritic’

a diacritic is a non-native object in module X: it is only used when information from outside of X is processed. It is absent from events that do not appeal to extra-Xal information.

Since diacriticness is about alienness, the definition of what counts as a diacritic is necessarily in reference to some area. In a modular environment, reference is made to a module. According to (1), then, an object is a diacritic in phonology if it never occurs in module-internal computation, i.e. one that is unimpacted by morpho-syntactic information.

In turn, non-diacritic objects, i.e. those that qualify as carriers for morpho-syntactic information, are known to participate in phonological computation that is unimpacted by any morpho-syntactic condition. In short, truly phonological objects are simply those which make the input vocabulary of the phonological module.

Omegas (i.e. *Prosodic Words*, as much as other units of the *Prosodic Hierarchy*) and hash marks do not qualify because they only appear in processes that are impacted by morpho-syntactic information: they do not carry anything else. On the other hand, objects such as “labial”, “stopness” and the like pass the anti-diacritic filter: they are found in processes where morpho-syntactic information plays no role, and they have a phonological substance, i.e. they carry phonological information. The trouble is that these candidates for the representation of morpho-syntactic information are ruled out by the anti-melody filter that was discussed in the previous section.

The question, then, is what kind of item may pass both the anti-diacritic and the anti-melody filter. One answer is certainly syllabic space: syllabic constituents exist in phonological processes that are bare of any morpho-syntactic conditioning. Exactly what kind of item is inserted in the linear string, then, depends on the specific theory of syllable structure that is assumed. This indeterminacy is welcome since it allows phonological theories to be refereed not only on purely phonological grounds, but also according to their behaviour at the interface. That is, different theories of syllable structure propose different units for carrying morpho-syntactic information and hence make different predictions. Therefore the comparative merit of competing phonological theories may also be assessed at the interface.

Note that this contrasts with buffer-based theories of the interface: whatever the inherent contrast of phonological theories, it is levelled out at the interface since the representational means that are used at the interface – hash marks or the *Prosodic Hierarchy* – are the same for all phonological theories. Hence there is no theory-specific behaviour at the interface, and the interface will never be able to contribute an arbitral award to the competition of different phonological theories.

2.3. CV units carry boundary information in CVCV

The evaluation of different phonological theories according to their behaviour at the interface must be done elsewhere. In the discussion below, the

predictions of a specific theory of syllable structure, so-called *CVCV* (a development of Government Phonology, see Lowenstamm, 1996, Scheer, 2004, Cyran, 2003, Szigetvári, 1999, Szigetvári and Scheer, 2005), are made explicit. The pages below suppose some familiarity with this framework.

In *CVCV*, the inventory of autonomous syllabic items reduces to an onset followed by a nucleus, i.e. a CV unit. Empty CV units are thus the only representational items that may carry boundary-information. Lowenstamm (1999) has proposed that the contrast between those languages where only word-initial TR-clusters are allowed (TR-only languages) and those where any type of cluster occurs (anything-goes languages) is expressed by a CV unit, the so-called initial CV (see Scheer, 2004: §83 for an overview)⁶.

While the (word-)initial occurrence of CV units that carry morpho-syntactic information is best studied (e.g. , 2001a, 2005, 2008, Szigetvári, 1999, Seigneur-Froli, 2003, 2006), boundary information has also been found to be carried by CV units elsewhere: examples are the negative marker in Kabyle Berber (Bendjaballah, 2001), a verbal marker in Chleuh Berber (Lahrouchi, 2001), a tense marker in German strong verbs (Bendjaballah and Haiden, 2003a, b), the so-called derivational syllable of Guerssel and Lowenstamm’s (1990) analysis of Classical Arabic and the syllabic support for the aforementioned intrusive consonants in French that occur between the root and certain suffixes (e.g. *stabilo-t-er* “to mark with a Stabilo pen”, Pagliano, 2003).

2.4. The direct effect

In section 2.2 it was argued that the elimination of the layer of uniform interface vocabulary (hash marks and the units of the *Prosodic Hierarchy*) makes individual phonological theories predictive at the interface. The present section explains why this is so: the uniform interface vocabulary is necessarily made of diacritics, and diacritics are intrinsically unable to make predictions. This is because they are empty shells: they do not carry any information except the morpho-syntactic load that they are designed for.

Therefore phonology is unable to react on the simple presence of a hash mark or a *Prosodic Word* – these units are “sleepers”: they sit in phonology and are inert unless the analyst has made a phonological process sensitive to them. By contrast, if phonologically meaningful vocabulary carries morpho-syntactic information, its bare presence will influence phonological computation.

This is what I call the direct effect: the simple presence of phonologically meaningful objects makes predictions. By contrast, there is no way to know what kind of effect the presence of a hash mark or a *Prosodic Word* will have:

⁶ T is shorthand for any obstruent, R for any sonorant.

Under a there are two empty nuclei to be covered. In case of an initial #TR cluster (i.e. a branching onset in regular terminology), the sonorant and the obstruent can establish a relationship (“<=”) which circumscribes the intervening empty nucleus; therefore the first filled nucleus of the word can govern the empty nucleus of the initial CV. The structure is therefore well-formed. The same is not true for initial #RT, #TT and #RR clusters, though, whose consonants cannot establish any relationship: this is the translation of the opposition between branching onsets and coda-onset clusters in *CVCV* (Scheer, 2004 and Ségéral and Scheer, 2008 discuss this contrast at greater length). There are thus two empty nuclei in a row that require government, and the structure is ill-formed.

By contrast under b where the initial CV is absent, there is only one empty nucleus to be governed whatever the word-initial cluster, and this can be done by the first filled nucleus of the word. Hence both #TR and #RT clusters are well-formed in this kind of language⁸.

a and b thus represent the parametric split between TR-only languages such as English, Italian etc. where word-initial clusters are only #TR, and anything-goes languages such as Moroccan Arabic where clusters of any sonority slope are well-formed at the beginning of the word.

Beyond the regulation of word-initial clusters, the initial CV impacts phonology in two other ways (Scheer, 2004: §87, forthcoming a, Ségéral and Scheer, 2008): its presence makes word-initial consonants strong (while they are weak in its absence) and enforces the presence of the first vowel of the word (while this vowel may be absent in absence of the initial CV). This is illustrated under below.

(5) presence vs. absence of the initial CV (effects two and three)

a. initial simplex C: initial CV present b. initial simplex C: initial CV absent

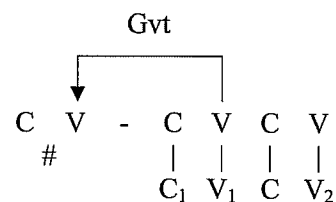

#C strong: it escapes Gvt
V₁ cannot be absent: two empty nuclei in a row

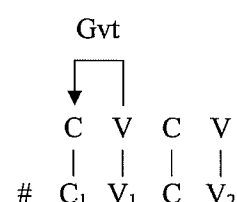

#C is governed (=intervocalic)
V₁ can be absent: only one empty nucleus

⁸ Unless otherwise specified, #RT is shorthand for all initial non-TR clusters, i.e. #RT, #RR and #TT.

Under a, the first filled nucleus of the word must govern the empty nucleus of the initial CV. Therefore the word-initial consonant escapes government, whose effect is to inhibit the segmental expression of its target. The un-governed C₁ under a is thus strong in terms of the Coda Mirror (Ségéral and Scheer, 2001a, 2008).

By contrast under b, the first nucleus of the word has no governing duty and therefore targets C₁, which is weak. The alliance of the effects on clusters and word-initial consonants is tested by Seigneur-Froli (2003, 2006) on the grounds of the Greek pattern. While French for example is TR-only and has word-initial consonants that are strong in diachronic evolution, Greek has also non-TR initial clusters (#pt, #kt, #mn) and at the same time weak word-initial consonants: in the evolution from Classical to Modern Greek, word-initial consonants spirantize just like their intervocalic peers (*t^halasa* θάλασσα > *thalasa* θαλασσα = *othonjon* ὀθόνιον > *othoni* οθονη), while post-obstruent consonants resist spirantization (*op^hthalmos* ὀφθαλμός > demotic *oftalmos* οφθαλμός).

Regarding the third effect, the absence of the first vowel of the word produces an ill-formed structure under a since it creates a sequence of two empty nuclei. Under b where the initial CV is absent on the other hand, nothing withstands the first vowel of a word to alternate with zero: it may always be governed by the following nucleus, which has no other governing duties. Czech for example illustrates this pattern: *pes* “dog Nsg”, *ret* “lip Nsg”, *len* “flax Nsg” appear as *ps-a*, *rt-u*, *ln-u* in Gsg, and this concords with the fact that Czech is an anything-goes language (i.e. has words with non-TR-initial clusters: *lžíce* “spoon”, *rtut* “quicksilver”, *rdít se* “to go red”, *rvát* “to tear”, *mdlít* “to faint”, *mžít* “to drizzle” etc.).

In sum, thus, the parameterisation of the initial CV has (at least) three empirical consequences, which the theory predicts to co-occur in the way shown under below.

(6) typological predictions made by the parameterisation of the initial CV

in a language where the initial CV is present	in a language where the initial CV is absent
a. word-initial consonants are strong	word-initial consonants are non-strong
b. first vowels of words may not alternate with zero	first vowels of words may alternate with zero
c. word-initial clusters are restricted to #TR	there are no restrictions on word-initial clusters: #TR, #RT, #TT and #RR may freely occur

Note that these predictions are anything but trivial: they chain together three empirical situations that otherwise seem to be unrelated. Also, they are empirically explicit and may be easily falsified: any language that displays one of the three properties of the righthand or the lefthand column under must also instantiate the two other properties of the same column. Space restrictions preclude further discussion of the empirical record, whose response is rather encouraging (see Scheer, 2004: §87, Ségéral and Scheer, 2008 for greater detail).

3. Procedural communication with phonology

3.1. Process-specific PIC

Let us now look at the other potential sandhi-blocker, *Phase Impenetrability (PIC)*. A classical and cross-linguistically pervasive observation is that cross-word phonology is process-specific. It is not true that languages always set a binary parameter that defines whether phonological processes do or do not apply across word boundaries. Typically some processes do, while others are blocked. Hence if the *PIC* is responsible for sandhi-blocking, it must apply to processes à la carte.

The process-specificity of the *PIC* may be illustrated in English: stress assignment is strictly limited to the word, but there is a lot of (external) sandhi. As indicated by its name, word stress is strictly bound by the limits of the word. It was already mentioned that affix classes bear on stress placement: in the traditional SPE-terminology, affixes may be stress-shifting (*párent - parént-al*) or stress-neutral (*párent - párent-hood*). Stress placement is always calculated with respect to the right edge of the word: in our example it is always penultimate (*párent - parént-al*), except when the morpheme boundary of class 2 affixes interferes, in which case the root is treated as a stress-relevant domain (i.e. a word) in its own right (*párent-hood*). The domain of stress-assignment is thus either the word or a subset thereof, the root – but never any chunk larger than the word. That is, there are no cases where word-stress would be calculated for a unit of, say, two words: the stress of *parént-al* will not shift when another word is added. *Paréntal tasks* bears two independent word stresses, and there is no global calculus that would produce something like **parentál tasks*, i.e. where penultimate stress is assigned to the domain [parental tasks] that is made of both words⁹.

⁹ It is true that word stress may be subject to further modification in external sandhi: the contrast between *thirtéen* and *thirteen mén* illustrates the well-known pattern of so-called stress clash that modifies word stress when two word stresses are adjacent (LIBERMAN and PRINCE, 1977 and subsequent literature). Obviously, however, this is an independent phonological process that has got nothing to do with word stress

Word stress thus indicates that there is some barrier that prevents phonology from applying to chunks that are larger than the word: we are in presence of a sandhi killer. This does not mean, however, that there are no phonological processes in English that apply across word boundaries. One was already mentioned in note : stress clash. Another is t-flapping that occurs in certain (American) varieties (Kahn, 1976 and much subsequent literature): according to standard descriptions (e.g. Nespór and Vogel, 1986: 46 f., 224 ff.), flapping applies in whatever syntactic environment provided the /t/ is word-final and intervocalic. Hence [r] appears word-internally in *city* and *atom* (word-internally, the /t/ must also be post-tonic), but also word-finally in *at issue*, *a white owl*, *invite Olivia*, *at eleven* or *just the other night a racoon was spotted in our neighbourhood*.

A hard fact about sandhi phonology is thus its process-specificity. Phonologists have tried to accommodate this situation in various ways. One is to have a more fine-grained (i.e. weaker) definition of Phase Impenetrability: previously interpreted strings are not frozen altogether; rather, only those phonological properties that are due to previous phonological computation are frozen, i.e. cannot be undone. This is Kaye's (1992, 1995) solution. In this perspective, further stress shift after the word level is blocked because stress was assigned by previous computation. By contrast, flapping across word boundaries can go into effect because the /-t/ was not modified by previous phonological action.

Another way of expressing roughly the same idea is the distinction between structure-building and structure-changing processes that was introduced in the 80s in order to rescue the *Strict Cycle Condition (SCC)* which stipulates that rules apply only to derived environments (Kiparsky, 1982a: 46 ff., 1982b: 160 ff., see Scheer, forthcoming a, b). Structure-building operations such as stress assignment (on the assumption that stress incarnates as metrical structure, i.e. grids or feet) were allowed to apply to non-derived items (Halle and Vergnaud, 1987: 84 ff.), while structure-changing operations such as segmental changes (i.e. which modify pre-existing structure) – flapping in our case – can only apply to derived environments. An environment was derived either when the string was heteromorphemic, or when the target of the modification was the result of the application of a previous phonological process. The latter condition describes the same situation as Kaye's version of the *PIC*: items can-

assignment: it further modifies the *result* of word stress and obeys triggering conditions that are completely different from those that define word stress assignment. We are thus in presence of two distinct phonological processes. The generalization to be made below is simply that the phonological mechanism which is responsible for word stress is strictly bound by the limits of the word.

not be further modified if they are the result of the application of a phonological process¹⁰.

Another approach to the process-specificity of sandhi-blocking is – cast in modern vocabulary – to make *Phase Impenetrability* phase-specific. In the vocabulary of the 80s, Mohanan and Mohanan (1984) and Halle and Mohanan (1985: 95 ff.) argue for the stratum-specificity of the *SCC*: in English, stratum 1 is, but stratum 2 is not cyclic (that is, stratum 1 does, but stratum 2 does not respect the *SCC*/the *PIC*).

A more direct implementation of process-specificity is the core idea of *Lexical Phonology* according to which word- and sentence phonology, i.e. the phonology of strings of morphemes and the phonology of strings of words, are two distinct computational systems, lexical and post-lexical. Individual rules are assigned to either, or to both. In our example, the word stress rule will be part of the lexical, but not of the post-lexical phonology. By contrast, flapping is present in both computational systems.

Finally, the alternative that I consider in Scheer (2009, forthcoming a) is also a faithful transcription of the observational fact: a process-specific *PIC*. That is, it is specified for each process whether its application is subject to the *PIC* or not. In our example, stress assignment is, flapping is not. The difference with respect to the lexical vs. post-lexical distinction of *Lexical Phonology* is that there is only one computational system, i.e. only one phonology (one set of rules, one constraint ranking). Process-sensitive *PIC* has also been proposed in syntax (Bošković, 2007), and is implied by Marvin's (2002) analysis of English stress (where secondary, but not primary stress is marshalled by the *PIC*).

At the bottom line, it may be concluded that it is certainly necessary and useful to determine the phase structure of a language – knowing its precise contours, however, does not reveal much about the phonological consequences of phases since *Phase Impenetrability* (i.e. sandhi-blocking) is not an automatic consequence of a phase.

3.2. The initial CV is out of business for process-specific patterns

Process-specific sandhi blocking may also be (and commonly is) analyzed in terms of the *Prosodic Hierarchy*, i.e. representationally. In the perspective of *Prosodic Phonology*, this is indeed straightforward since as in *Lexical Phonol-*

¹⁰ Flapping in monomorphemic roots (*city*, *atom*) should be ruled out even when Kiparsky's distinction between structure-building and structure-changing operations is applied. The way out of this is to assume that the flap in monomorphemic items is lexically recorded: there is no evidence for an underlying /t/ (except spelling and its diachronic identity). But this discussion is idle anyway since KIPARSKY (1993) has declared the bankruptcy of the entire derived environment programme.

ogy, individual phonological processes are associated to a specific domain of application: we have seen in section 1 that on one possible analysis, the application of nasal assimilation in English is restricted to the *Prosodic Word*. Unlike in *Lexical Phonology*, though, the domain-specificity of phonological processes is done in the frame of one single computational system.

In principle, this option is not available when the representational carrier of morpho-syntactic information is a CV unit. Beyond the diacritic issue, the fundamental difference between the arboreal structure of the *Prosodic Hierarchy* and a CV unit is the fact that the latter is a *linear object*: it is inserted into the linear string and hence precisely located as an item that follows morpheme X and precedes morpheme Y. There is no way to talk about the linearized CV in terms of a domain: like SPE's hash mark, it defines a specific *point* in the linear string. Conversely, there is no way to talk about the domains that are defined by the *Prosodic Hierarchy* in punctual terms, or in terms of linear precedence: a unit of the arboreal structure, say, the *Prosodic Word*, is not located between any two morphemes – it spans a number of them (Scheer, forthcoming a discusses this difference at greater length).

Therefore individual processes cannot be associated with a specification for any domain of application: the CV unit does not define any such domain. Rather, it is part and parcel of the string that is submitted to the phonological module for computation. Since modules cannot backtrack the origin of the items that they work on, the CV unit that represents morpho-syntactic information and any other CV unit that belongs to a specific morpheme are indistinguishable. As a result, once a CV unit is inserted into the input string to phonological computation, it cannot disappear or be selectively “seen” by individual phonological processes.

A la carte-visibility of the CV unit is precisely what Balogné-Bérces (2004, 2005) proposes: each phonological process is specified for ignoring (flapping in our case) or not ignoring (word stress) CV units that carry morpho-syntactic information, which are present anyway. For the reasons mentioned, this does not appear to be an option: phonology is unable to tell “morpho-syntactic” and “truly phonological” CV units apart. Also note the contrast with respect to the perspective of *Prosodic Phonology* where nothing has to be “switched off” of made “invisible” (arboreal structure is appealed to or not by a rule).

Finally, another reason that makes à la carte-visibility incompatible with *Direct Interface* is that it revives the functioning of diacritic SPE-type hash marks. These were inserted into the linear string, but had no effect unless they were appealed to by a rule. CV units that are only “switched on” for certain processes are the same kind of “sleeper”. Being a “sleeper”, though, is the trademark of diacritics: the goal of *Direct Interface* is precisely to do away with

representational items that are inserted into the phonological string but do not have any effect (see section 2.4).

4. *The initial CV and connected speech in Corsican*

4.1. *Introduction*

Let us now look at a concrete case of external sandhi that may illustrate the general pattern. The goal is to evaluate the consequences of the initial CV in this context. We will see that it cannot be present when phonology applies across word boundaries since it would block external sandhi. The question, then, is how this relates to the fact that TR-only languages, which are supposed to possess the initial CV, may also show external sandhi. The language chosen, Corsican, is precisely of this kind: TR-only *and* accommodating connected speech.

Before looking at the data, a disclaimer is in order: up to this point, connected speech was presented as a binary phenomenon, i.e. which either does or does not apply across word boundaries. However, many phonological processes apply across certain word boundaries, but not across others, depending on the syntactic relationship. Much of the *Prosodic Phonology* literature is concerned with determining the exact syntactic conditions of connected speech. The example of English flapping was chosen on purpose because it is usually described as a process that applies across word boundaries no matter what their syntactic nature (e.g. Nespov and Vogel, 1986: 225).

The dialects spoken in the central part of the Italian peninsula are known for connected speech phenomena. The area includes varieties such as Sardinian, Tuscan and Corsican (e.g. Giannelli and Savoia, 1978, Contini, 1986, Dalbera-Stefanaggi, 2001a). A case in point is Gorgia Toscana, a spirantization (see Marotta, 2000-01, 2008) that applies intervocally no matter whether the preceding vowel belongs to the same word or not and, according to Marotta (2008), irrespectively of the kind of syntactic division. The Corsican pattern that is studied below is similar in that specific syntactic divisions are not reported to play any role.

4.2. *Strong and weak positions and the expression of positional strength*

In Corsican, word-initial consonants have strong and weak alternants, which are selected according to positional parameters. Table (7) below shows their distribution.

- (7) distribution of strong and weak alternants of word-initial consonants
- a. weak alternants occur after vowels
 - b. strong alternants occur everywhere else:
 1. after words that end in a floating consonant
 2. after words that end in a stable consonant
 - (3. after a pause, i.e. utterance-initially)

This is the description provided by Dalbera and Dalbera-Stefanaggi (2004: 420)¹¹. The phenomenon at hand is called Corsican consonant mutation; its various aspects (dialectal, geographic, sociological etc.) are discussed in (1977, 1981, 1991, 2001b)¹².

In absence of the influence of specific syntactic divisions, the only relevant factor to be considered is thus the position of the word-initial consonant, which may be utterance-initial (i.e. occur after a pause), follow a consonant-final or a vowel-final word.

Segments thus stand in strong position in three environments. The expression of this positional strength is twofold: either actual strengthening is observed, or the segment resists lenition (which occurs elsewhere). That strong positions may have these two effects has also been observed by Ségéral and Scheer (2001b) in a study of the evolution of Latin *C+yod* sequences in French: non-lenition is an expression of segmental strength.

In the Corsican case, the two ways of expressing strength are distributed according to the context: gemination (i.e. actual strengthening) is found after words that end in a floating consonant (and also utterance-initially, on which more in section 4.5), while the underlying segment is protected against lenition after consonants. This distribution is discussed as the analysis unfolds¹³.

¹¹ We will see below that the empirical situation allows only for a limited exploitation of the utterance-initial context. Also note that the dialectological literature describes words that end in a floating consonant as ending in a tonic vowel (whose stress is the reflex of the loss of the final consonant). Section 4.4 below discusses the synchronic reality of the floating consonants in question.

¹² Corsican is actually a cover term for a number of dialectal varieties. All of them display the strong-weak allophony of word-initial consonants. Individual varieties, however, vary with respect to the systematicity of the alternation, the consonants that participate and the allophones that represent them. The most complete picture is found in the Centre-South area, from which all data quoted are taken. Extensive discussion of the dialectal variation together with richer material may be found in DALBERA and DALBERA-STEFANAGGI (2004) and in the literature that is quoted in the main text.

¹³ A word on the practice of transcription in the dialectological literature. Traditionally, the important distinction is between strong and weak versions of segments. How strong consonants are actually pronounced is secondary (and variable across

4.3. A strong sonorant is a stop, but a strong stop is a geminate

Table (8) below provides illustration of the alternations encountered (see Dalbera and Dalbera-Stefanaggi, 2004: 420 f.). For the sake of presentation, only two strong positions are mentioned for the time being: strong 1 (words that end in a floating consonant) and strong 2 (words that end in a stable consonant). That the words of the former really bear a floating consonant is demonstrated in the following section. For the time being, there is no visible difference between the words that trigger the strong 1 position (such as *tre* “three”) and those that produce weak results (such as *u* “the”): both are vowel-final on the surface. The remaining strong position, i.e. when consonants are utterance-initial, is discussed in section 4.5 below¹⁴.

dialects). Therefore much of the dialectological literature uses a binary diacritic that indicates only if a given segment is strong or weak. The diacritic at hand is a macron superimposed over the consonant. Hence *pane* “bread” will appear as [tre 'pāni] “three breads” in strong, but as [u 'bane] “a bread” “in weak position. Since the most frequent realisation of strong consonants is gemination, the macron has become a general-purpose notation for anything that appears to be strong, even in case it is unrelated to strengthening. That is, word-internal geminates which are part of the lexical information of words may also be transcribed by a macron: ['fau] “done” vs. ['fata] “fairy”.

It is therefore impossible to know what the exact value of macron-bearing consonants is just by looking at the transcription. Moreover, the dialectological literature sometimes reconverts the macron-notation into a geminate-notation for this reason: the most frequent realisation of strength is gemination. In this case, the naïve reader may mistakenly interpret the [dd] of a notation such as [un 'ddente] “a tooth” as a geminate.

In practice, then, macron-augmented consonants and notations repeating the letter of a consonant are used quite synonymously. The only thing that may be concluded when coming across either is that the consonant at hand is strong. Its actual pronunciation (single or double) is a matter of further interpretation. Since the distinction between the realisation of strong consonants as geminates and as singletons is critical for the demonstration, every individual pronunciation that is mentioned below was checked with Jean-Philippe Dalbera and Marie-Josée Dalbera-Stefanaggi, to whom I am indebted for advice and control of the empirical situation. A repeated letter only refers to true geminates, and the only transcription of geminates is by a repeated letter.

¹⁴ Note that two oppositions are neutralised in the entire language and hence do not produce any contrast in the table below: ff-f (in favour of ff) and rr-r (in favour of r). Glosses (line by line): /p/ three breads, a bread, the bread; /b/ he has seen, in order to see, they have seen; /f/ these are stories, in stories, this looks like stories; /t/ touch ground, in the ground, the earth (ground); /d/ these are teeth, a tooth, two teeth; /ts/ these are ticks, in ticks, a tick; /s/ three pennies, a penny, no pennies; /c/ he is short, a short, the short; /k/ by strokes, a stroke, two strokes; /g/ three faces (pej.), in the face, of the face; /j/ this is wheat, in wheat, the wheat; /j/ three games, by the game, the game; /m/ he is dead, in order to die, he was dead; /n/ he is born, in order to be born, he was born; /r/ three toads, a toad, the toad; /l/ he has read, in order to read, they have read.

(8) Corsican consonant mutation

alternation	strong 1	strong 2	weak
	(C) # <u>V</u>	C # <u>V</u>	V # <u>V</u>
pp-p-b	tre 'ppani	un 'pane	u 'bane
bb-b-w	a 'bbiʃtu	per 'beðe	'anu 'wiʃtu
ff-ff-v	so 'ffole	in 'ffole	'parenu 'vole
tt-t-d	tukka 'ttaerra	in 'taera	a 'daera
dd-d-ð	so 'ddenti	un 'dente	'dui 'ðenti
tts-t̄s-d̄z	so 'tts̄ekki	in 'ts̄ekki	'una 'dz̄ekka
ss-s-z	tre 'ssoldi	un 'soldu	mikka 'zoldi
cc-c-ʃ	ε 'ccugu	un 'cugu	u 'juɡu
kk-k-g	a 'kkolpi	uŋ 'kolpu	'dui gɔlpi
gg-g-w	tre 'ggole	iŋ 'gola	di 'wola
ʃt-ʃt	tre 'ʃjogi	per 'jogu	u 'jogu
mm-m-m	ε 'mmortu	per 'more	'era 'mortu
ɲt-ɲt-n	ε 'ɲɲadu	per 'ɲaʃe	'era 'nadu
ʎt-ʎt	a 'ʎlettu	per 'ʎeje	'anu 'lettu
r-r-r	tre 'rɔspi	un 'rɔspu	u 'rɔspu

The table shows that we are actually facing a system with three, rather than with two degrees of strength: obstruents and sonorants do not behave in the same way when exposed to positional strength. In weak position, the result of a lenited obstruent (in the first half of the table) is voicing (for voiceless items) or spirantisation (for voiced items). In strong 1 position, stops geminate, while they appear in their underlying coat in strong 2 position where neither lenition nor strengthening occurs: as was mentioned earlier, non-lenition is a form of strength.

Sonorants of course cannot behave along the same lines: they are already voiced (also, the voicing is not of the same kind as in obstruents), and it is not clear what a spirantised sonorant would look like. Therefore, observing the second half of the table, the only consistent interpretation is that the underlying object appears in weak position, rather than in strong 2 position as is the case for obstruents. This in turn means that sonorants have two distinct ways of expressing strength, which may combine and occur according to the kind of strong position that is encountered: either they only show melodic strengthening (in strong 2 position, e.g. /j/ → [j̄]), or this melodic strengthening is accompanied by gemination (in strong 1 position, e.g. /j/ → [jj]). Melodic strengthening affects glides, which become stops (/j/ → [j̄]) and nasals/laterals, which

become retroflex¹⁵. Table (9) below shows the ensuing three-step scale.

(9) three-step scale of Corsican strengthening

degree 2: geminates	ʃʃ, ɲɲ, ll	pp,bb,tt,dd,ʃʃ,ss,cc,kk,gg
	↑	↑
degree 1	ʃ, ɲ, l	p,b,t,d,ʃ,s,c,k,g
	↑	
degree 0: sonorants	j, n, l	

Another way to look at this picture is through the effect of the two strong positions: while the strong 1 position always produces a measurable result (gemination), the strong 2 position seems to affect only sonorants. Obstruents appear in their underlying coat and hence seem to show no reaction (but recall that non-lenition is a form of strength). In other words, the strong 1 position (effect: strengthening) appears to be stronger than the strong 2 position (effect: strengthening of sonorants, non-lenition of obstruents).

4.4. *Words that end in a floating consonant: evidence for the floater*

Knowing about their effects, let us now look at what makes the difference between the two strong positions in terms of the triggering conditions. Recall that word-initial consonants stand in strong 1 position when the preceding word ends in a floating consonant. On the surface, though, the floating consonant is absent in normal circumstances. Only its effect is visible under (8), where vowel-final words sometimes provoke the strong alternant of the following consonant (in the strong 1 column), but at other times produce the weak form (in the weak column). The effect is obvious, but there must be a means to tell words such as *tre* “three” (which produces the strong 1 effect) from words such as *u* “the” (which provokes lenition) on independent grounds.

Diachronic as well as synchronic evidence shows that there is indeed a final consonant around in the former, but not in the latter class of words. That is,

¹⁵ The situation of /w/ is intricate: in some varieties, its strengthened version is [gʷ], but in others it is interpreted as a weak version of /b/, and thus produces [b] in strong position. Given this additional complication, /w/ remains unillustrated. Also note that the bilabial nasal /m/ of course cannot express its strength melodically by becoming retroflex. Finally, recall that the opposition between simple and geminated r is neutralised in favour of the former in the entire language.

words of the *tre* class were consonant-final in Latin, while words of the *u* class have vowel-final Latin ancestors. This is shown under (10) below¹⁶.

(10) complementary distribution of strong 1 and weak V-final words according to diachronic origin

Latin	Corsican	gloss	Latin	Corsican	gloss
AD	<i>a(ð)</i>	to	HABENT	<i>'anu</i>	they have
CUM	<i>iqku(m)</i>	with	ILLA	<i>a</i>	the (fem)
ET	<i>e(ð)</i>	and	ILLU(M)	<i>u</i>	the (masc)
EST	<i>ε</i>	is	DE	<i>di</i>	from
HA(BE)T	<i>a</i>	s/he has	ERA(T)	<i>'era</i>	was
NON	<i>un</i>	not			
PER	<i>pe(r)</i>	in order to			
SUNT	<i>so</i>	are			
TRES	<i>tre</i>	three			

In one way or another, the Latin word-final consonant must still be active in present-day Corsican phonology: it produces an effect on consonants that belong to another word, which excludes a perspective where the result is lexicalised. An obvious solution is a floating status of the kind that is known from liaison consonants in French (Encrevé, 1988).

On the synchronic side, the floating consonant of the *tre* class appears on the surface when the syntactic distance with the following word is sufficiently small: *að 'ella* “to her”, *eð 'ellu* “and he”, *iqkum 'ella* “with her”. The consonants in question may also appear in high style (e.g. the *-ð* in *liber'tað e verti'ta* “freedom and truth”). Finally, words with floating consonants such as *pe(r)* produce free variation: the first consonant of the following word may or may not appear as a geminate, e.g. *per te - pe tte* “for you”. In case a geminate is observed, however, the floating consonant is necessarily absent, while it appears when the following consonant has a non-geminate pronunciation. This clearly indicates that both words are in competition for a piece of (syllabic) space, which may either be used by the floating or by the word-initial consonant (but not by both).

¹⁶ Note that the Latin accusative singular marker *-M* had already disappeared in late Latin and therefore does not impact Corsican (BELLUM TEMPUS > [bællu 'dempu]). Its absence in late Latin is shown by the fact that the preceding vowel could be elided before a following vowel-initial word in poetic scansion (e.g. NIEDERMANN, 1985: 101 ff.). Also note that the final vowel of Corsican [anu] < HABENT is not of Latin origin. This is why the final Latin consonant of this word plays no role in Corsican: word-initial consonants following [anu] are in weak position (e.g. [anu 'wistu] “they saw”).

In conclusion, table (11) below shows the representation of the three relevant types of words and the way in which V-final words that do and do not provoke following strong consonants are distinguished.

(11) floating consonants in Corsican

a. V-final word with a C-final ancestor	b. C-final word	c. V-final word with a V-final ancestor
C V C V	C V C V	C V
p ε r	u n	d i
a d		

Note that the floating consonant under (11)a is accompanied by an empty CV unit, which is needed when the consonant is actually pronounced (as in *per tε* “for you”) and receives the second half of the word-initial consonant in case gemination occurs (*pe tte* “for you”, see below).

4.5. The utterance-initial position is strong

Finally, let us consider the utterance-initial situation. Gemination only occurs in high (declamatory) style, but is an option. Also notice that when utterance-initial geminates are encountered, they are optionally accompanied by a prothetic vowel. For example, “this book” may be pronounced *ssu 'libru* or *issu 'libru*, and “remember! (2 pl)” may appear as either *rrikur'dassi* or *arrikur'dassi*¹⁷.

Consonants in utterance-initial position thus normally pattern with the utterance-internal strong 2 position ($C\# _ V$, result: non-lenition), but may occasionally behave like in strong 1 position ($(C)\# _ V$, result: gemination). In any event, there is no lenition in this environment: utterance-initial consonants are strong. This supposes the presence of an initial CV unit in utterance-initial position.

4.6. The post-consonantal position is strong, but prohibits gemination

Let us now address the question why the two strong positions (strong 1 and strong 2) produce different effects. We know that the latter (i.e. after C-final words) is strong because it triggers melodic strengthening of sonorants. The former (i.e. after floating consonants) produces the same effect on sonorants,

¹⁷ Giovanna Marotta has pointed out to me that the same pattern is found in Central and Southern Tuscan (Volterra, Siena, S. Vincenzo) where the definite article sg. may be a long [l] in utterance-initial position, e.g. *ll'acqua* “the water”, *ll'olio* “the oil”.

but in addition causes gemination of both sonorants and obstruents.

Descriptively, both positions are strong, but gemination in post-consonantal position (strong 2) does not occur. It may thus be concluded that the blocking of gemination has got nothing to do with positional strength: the strong 2 position in itself is strong whatever the segment that it contains – only does it not allow for consonants to express this strength by gemination, which is prohibited for some independent reason.

On this count, both strong environments issue a call for strengthening. According to their segmental identity, all segments “try” to strengthen, but one particular result, gemination, is blocked in one particular environment, after an expressed consonant. The strength of this position is expressed by actual melodic strengthening of sonorants on the one hand, and by non-lenition of obstruents on the other.

That gemination cannot go into effect after consonants does not come as a surprise: geminates are typically intervocalic and normally unable to occur in the vicinity of other consonants. Once the different “strategies” of strengthening are understood (melodic strengthening vs. gemination), thus, the only thing that needs to be explained is the impossibility for geminates to exist in post-consonantal position, as opposed to their occurrence after floating consonants.

Let us take stock of this generalisation. Before an analysis of the pattern is presented from section 4.8 on, the fact that synchronic and diachronic evidence concords is shown in the following section.

4.7. Synchronic word-initial vs. diachronic morpheme-internal behaviour of consonants

Dalbera and Dalbera-Stefanaggi (2004: 416 f.) argue that Corsican consonant mutation is the result of two independent processes: underlying segments are either affected by lenition, or by fortition. They ground this scenario on a comparison with the morpheme-internal situation: while lenition of word-initial consonants is strictly identical with the (diachronic) movement of their morpheme-internal peers, strengthening by gemination has no parallel inside morphemes. Hence the two processes must be independent.

The present section illustrates the fact that (morpheme-internal) diachronic and (word-initial) synchronic alternations are exactly parallel, except for gemination. That is, the same melodic strengthening that is active in post-consonantal position and the same lenition in intervocalic position that is found synchronically occurred in the evolution from Latin to Corsican.

Let us begin with the weak intervocalic position. The lenition of word-initial consonants in this environment is strictly identical with the lenition of word-internal intervocalic consonants that has occurred diachronically. The only difference is that consonants in morpheme-internal position are not sub-

ject to any synchronic alternation since their environment cannot be modified. Table (12) below provides illustration (the synchronic word-initial situation is recalled in the first column for convenience).

(12) evolution of Latin consonants in Corsican I
intervocalic position

word-initial alternation (underlying - V # _ V)	evolu- tion	Latin V _ V	Corsican V _ V	gloss
<i>p-b</i>	<i>p-b</i>	<i>apis</i>	<i>'abε</i>	(honey) bee
<i>b-w</i>	<i>b-w</i>	<i>faba</i>	<i>'fawa</i>	broad bean
<i>t-d</i>	<i>t-d</i>	<i>sēta</i>	<i>'sēda</i>	silk
<i>d-ð</i>	<i>d-ð</i>	<i>nīdus</i>	<i>'ni ðu</i>	nest
<i>s-z</i>	<i>s-z</i>	<i>causa</i>	<i>'kɔza</i>	thing
<i>k-g</i>	<i>k-g</i>	<i>focus</i>	<i>'fogu</i>	fire
<i>g-w</i>	<i>g-w</i>	<i>fāgus</i>	<i>'faw</i>	beech tree
<i>j-j</i>	<i>j-j</i>	<i>major(e)</i>	<i>ma'jɔ</i>	oldest (son)
<i>w-w</i>	<i>w-w</i>	<i>ūva</i>	<i>'uwa</i>	grape
<i>m-m</i>	<i>m-m</i>	<i>homo</i>	<i>'omu</i>	man
<i>n-n</i>	<i>n-n</i>	<i>plēna</i>	<i>'piena</i>	full (fem)
<i>l-l</i>	<i>l-l</i>	<i>ala</i>	<i>'ala</i>	wing
<i>r-r</i>	<i>r-r</i>	<i>mare</i>	<i>'mare</i>	sea

Let us now consider strong positions. Of course, only the post-consonantal environment can be tested: floating and utterance-initial consonants do not occur morpheme-internally. Table (13) provides illustration (as before, the word-initial situation is recalled in the first column for convenience).

(13) evolution of Latin consonants in Corsican II
post-consonantal position

word-initial alternation (underlying - C # _ V)	evolu- tion	Latin C _ V	Corsican C _ V	glosses
<i>p-p</i>	<i>p-p</i>	<i>campus</i>	<i>'kampu</i>	field
<i>b-b</i>	<i>b-b</i>	<i>herba</i>	<i>'arba</i>	grass
<i>t-t</i>	<i>t-t</i>	<i>mortis</i>	<i>'morte</i>	death
<i>d-d</i>	<i>d-d</i>	<i>tardus</i>	<i>'tardu</i>	late
<i>s-s</i>	<i>s-s</i>	<i>ursus</i>	<i>'ɔ(t)su</i>	bear
<i>k-k</i>	<i>k-k</i>	<i>furca</i>	<i>'fɔrka</i>	fork
<i>g-g</i>	<i>g-g</i>	<i>longus</i>	<i>'lɔŋgu</i>	long
<i>j-j</i>	<i>j-j</i>	<i>area</i>	<i>'arja, 'aja</i>	ram (zool.)
<i>m-m</i>	<i>m-m</i>	<i>dormi(t)</i>	<i>'dormε</i>	he sleeps
<i>n-n</i>	<i>n-n</i>	<i>furnus</i>	<i>'fɔrŋu</i>	oven

As before, the word-initial and the morpheme-internal record coincide. That is, obstruents appear in their underlying coat (i.e. neither geminated nor lenited), while sonorants show melodic strengthening.

Since morpheme-internal consonants are synchronically invariable, phonologists will most probably conclude that the diachronic process observed is synchronically inactive. That is, there is no difference between the underlying and the surface form of the consonants at hand. While this holds true for the morpheme-internal situation, we know from the behaviour of word-initial consonants that lenition and fortition must still be active in the synchronic grammar of Corsican: sequences of words are not recorded in the lexicon (except for idioms and the like).

The bottom line of this demonstration is that Corsican ignores word boundaries: the result is identical word-initially (synchronic variation) and morpheme-internally (diachronic variation).

4.8. *Why consonants can geminate after floating,
but not after stable consonants*

We now turn to the analytic part of the study. Let us first consider the question why consonants can geminate after floating, but not after stable consonants. The answer is given by the representations under (14) (recall from section 4.4 that the CV unit of floating consonants must still be present).

(14) word-initial consonants after floating and stable consonants I:
gemination

- a. after floating consonants:
/a 'kɔlpi/ → a 'kkɔlpi
"by hits"
- b. after stable consonants:
/un 'dente/ → un 'dente
"a tooth"

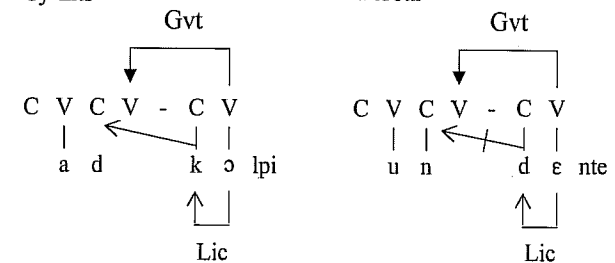

Under (14)b, gemination is blocked in post-consonantal position because the target onset for expansion is occupied by the final consonant of the preceding word. By contrast, gemination is possible after floating consonants under (14)a: the only difference is that these are unassociated. Therefore their onset is available for melodic identification and can receive the spreading of the following word-initial consonant.

That the word-final and the word-initial consonant really compete for the last onset of the first word is nicely demonstrated by the kind of free variation that was already mentioned in section 4.4: in a sequence such as /per tɛ/ "for you", speakers may pronounce the word-final consonant, in which case the following word-initial consonant remains ungeminated (*per tɛ*). Alternatively, the word-final consonant may be dropped, which provokes the gemination of the following word-initial consonant (*pe tte*)¹⁸.

4.9. Melodic strengthening is independent of syllabic space

The representations under (14) show in which way the positions after floating and stable consonants are different. But they also show what unites them: word-initial consonants occur after a governed empty nucleus in both cases. In terms of the Coda Mirror (Ségéral and Scheer, 2001a, 2008), this means that they stand in strong position (see section 2.5).

The positional strength at hand is then expressed in different ways according to the properties of the segment that is affected: sonorants strengthen melodically without eating up additional syllabic space. Melodic strengthening is thus independent from the availability of an additional empty onset: it occurs both after floating and stable consonants. Relevant configurations are shown under (15) below¹⁹.

(15) word-initial consonants after floating and stable consonants II: melodic strengthening

- a. after floating consonants: /trɛ jɔgi/ → trɛ jɔgi "three games"
 b. after stable consonants: /per 'jɔgu/ → per 'jɔgu "by the game"

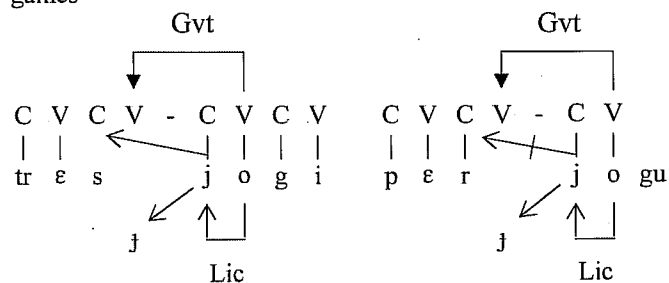

¹⁸ Giovanna Marotta points out that the same assimilation *per te* > *pette* occurs in informal speech in Tuscan.

¹⁹ Note that "tr" appears under a single C-slot under a for purely expository reasons: no heuristic value is attached to this representation.

Like obstruents, sonorants opportunistically geminate on top of carrying out melodic strengthening under (15)a, i.e. when an extra empty onset is available for expansion. After stable consonants as under (15)b, however, additional gemination is blocked because the target onset is occupied.

4.10. Utterance-initial consonants are strong because of the initial CV

Let us now look at the utterance-initial situation. Recall from section 4.5 that this position is strong: lenition is never observed, melodic strengthening occurs; however, gemination occurs only sporadically and in certain register-defined circumstances.

It was shown that the identity of all strong positions is to be preceded by an empty nucleus. Utterance-initial consonants must therefore follow an empty nucleus. In other words, the initial CV is distributed in utterance-initial position (but not in word-initial position, on which more below). Table (16) below illustrates the utterance-initial situation.

(16) consonants in utterance-initial position utterance-initial

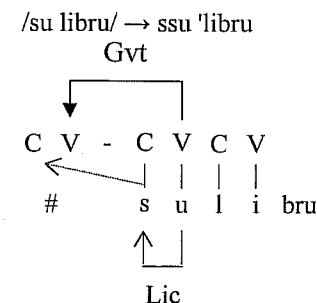

4.11. Weak positions and morpheme-internal consonants

Finally, let us consider the weak position, both word-initially and morpheme-internally. Table (17) below shows relevant configurations.

(17) the weak position: intervocalic consonants

- | | | |
|--|--|---|
| a. word-initial:
/u 'pane/ →
u 'bane | b. morpheme-
internal,
intervocalic:
lat. apis > 'abe | c. morpheme-internal,
post-consonantal:
lat. campus > 'kampu
lat. area > 'arja |
|--|--|---|

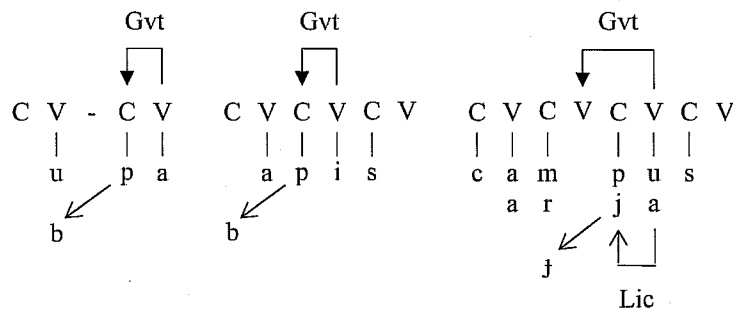

Word-initial and morpheme-internal consonants in intervocalic position under (17)a,b experience identical conditions: they are flanked by contentful nuclei, that is, they stand in true intervocalic position and therefore lenite.

By contrast, morpheme-internal consonants in post-consonantal position as under (17)c are preceded by an empty nucleus and a contentful onset, just like their word-initial peers after C-final words (see (14)b). The positional strength that consonants experience in this position guarantees obstruents against lenition, and triggers melodic strengthening of sonorants.

4.12. Conclusion: the initial CV occurs only utterance-initially

The basic observation when looking at the pattern described is that in Corsican word boundaries are irrelevant for phonology altogether (or at least for the calculus of consonantal strength). That is, phonological computation proceeds as if there were no syntactic divisions.

The only boundary information that impacts phonology is the marking of the utterance-initial position by the initial CV. Crucially, no CV unit must be distributed at the beginning of words: were words headed by an initial CV, all word-initial consonants would be strong. What is observed, though, is that their strength depends on the properties of the preceding word.

5. The distribution of the initial CV

On the basis of the Corsican pattern, let us take stock of the diagnostics that may be used in order to determine the (non-)distribution of the initial CV. We have seen that the initial CV must not be present when phonology applies across word boundaries. This diagnostic suffers no exception at least for processes that are conditioned by syllabic factors (i.e. involving constituent structure and lateral relations). That is, purely melody-driven processes such as, say, a palatalization, may well go into effect across word boundaries even with an intervening CV unit: the spreading of melodic items may be insensitive to extra space that needs to be crossed.

Another unmistakable diagnostic for the absence of the initial CV is the presence of RT-initial morphemes in a language. The occurrence of an initial CV at the left edge of words in anything-goes languages is out of the question since the structure created, /CV-RøTV.../, is ill-formed: two empty nuclei occur in a row, and their computation in the same phase is also guaranteed. The only way for anything-goes languages to accommodate a word-initial CV is the implementation of a repair mechanism such as epenthesis into the leftmost empty nucleus of /CV-RøTV.../: /rta/ would come out as [irta], while /ta/ would produce [ta]. If this kind of repair mechanism (consonant deletion would be another solution) is systematically observed word-initially with cluster-initial morphemes (but not with morphemes that begin with a single consonant), this can be ascribed to the presence of a word-initial CV.

On the other hand, a strictly TR-only lexicon does not allow for any conclusion regarding the distribution of the initial CV. Corsican is a strict TR-only language, but we have seen that this is not an obstacle for connected speech (which supposes the absence of the initial CV at the left edge of words). Put differently, there is no correlation between the kind of morpheme-initial clusters that the lexical inventory of a language allows for and external sandhi: Corsican is TR-only, but has no CV unit distributed at the left edge of words.

The Corsican case thus shows that while the presence of RT-initial morphemes enforces the absence of the initial CV in word-initial position, the absence of the initial CV in this position does not "force" a language to develop RT-initial words. Lexical properties impact grammar, but the reverse is not true – at least when all lexical items can "survive" computation without problem, which is the case in Corsican²⁰.

²⁰ Lexicon optimization describes a situation where lexical items are shaped according to the conditions that they experience during computation, but this concerns only those lexical items that will turn out to be ill-formed upon phonological computation for one reason or another ("prefer inputs that are well-formed outputs", e.g. HALE, 1973: 420, YIP, 1996, PRINCE and SMOLENSKY, 1993: §9.3).

Alongside these diagnostics for the absence of the initial CV, there are also diagnostics for its presence. This is when the two online effects of the initial CV are observed: if the initial consonant of words is strong no matter what (i.e. independently of the properties of the preceding word), or if the first vowel of words cannot alternate with zero no matter what (i.e. independently of the properties of the preceding word), words must be preceded by an empty CV unit.

It is useful indeed to distinguish online from lexical effects: table (6) has identified three correlates of the presence/absence of the initial CV. One is lexical and hence does not depend on phonological computation: we have seen that even though Corsican is strictly TR-only, it does not feature any word-initial empty CV unit. By contrast, the two other effects of the initial CV depend on online computation: vowel-zero alternations and the strength of consonants are the result of phonological operations. Hence if word-initial consonants are systematically strong irrespectively of the shape of the preceding word, or if first vowels of words are unable to alternate with zero in the same conditions, this must be due to the presence of an empty CV to their left.

In sum, thus, if the management of process-specific connected speech can only be procedural (see section 3.2), the management of the two online effects of the initial CV can only be representational.

6. Phonological and syntactic evidence for phase boundaries

6.1. What the initial CV is initial of are phases

In the above discussion we have come across two patterns: the initial CV may occur either word- or utterance-initially. These two chunks are defined on the basis of positive evidence: some languages show the two online effects of the initial CV at their left edge. Inside these chunks phonological computation is continuous: no edge-effects are observed within words (there is nothing like morpheme-initial strength) in those languages where the initial CV is word-initial, and edge-effects are not encountered within utterances in the other type of language (where phonology applies across word boundaries).

It may thus be concluded that the portions of the string that we are talking about are computational domains, i.e. phases in modern vocabulary. This means that what the initial CV is actually initial of are phases. The initial CV may therefore be regarded as a marker of phase boundaries. We have come across phonological evidence for two chunk sizes that have this status, but nothing indicates a priori that there is no language that shows phonological effects of phase boundaries for some intermediate chunk size, i.e. between the word and the utterance. At the same time, it is obvious that these two specific chunk sizes are critical and recurrent “barriers” for phonological processes across languages.

6.2. Phases may or may not leave phonological traces

Given our ability to detect phase boundaries on phonological grounds, an interesting question is of course how the phonological evidence for phases correlates with morpho-syntactic phase structure. The mapping is certainly not trivial. Chomsky's (2000) original take on phasehood identifies *CP* and *vP*, maybe *DP* (Chomsky, 2005: 17 f.), as phase heads. Since then there is a constant trend to grant phasehood to smaller and smaller chunks (den Dikken, 2007: 33 provides an overview): the *DP* track is followed, but *DP*-internal phases are also argued for (Matushansky, 2005). *TP* is another item under debate: while Chomsky (e.g. 2000: 106, 2004: 124) is explicit on the fact that *TP* does not qualify as a phase head (because it is not propositional), den Dikken (2007) points out that according to Chomsky's own criteria, this conclusion is far from obvious. *TP* is indeed assumed to act as a phase head in a growing body of literature, and nodes below *TP* such as *Voice⁰* (Baltin, 2007, Aelbrecht, 2008) and *AspP* (Hinterhölzl, 2006) are also granted phasehood. The vanishing point of the atomization of phasehood is a situation where all nodes trigger interpretation; or, in other words, where interpretation occurs upon every application of *Merge*. This radical position – Spell-out-as-you-Merge – is defended by Samuel Epstein and colleagues: Epstein et al. (1998), Epstein and Seely (2002, 2006).

The field is in steady movement, but even on the most conservative count, i.e. Chomsky's initial *vP* and *CP*, there is a “syntactic” phase between the word and the utterance: *vP*. Less conservative perspectives place many more phase boundaries in this area, none of which seems to leave phonological traces.

It is not really probable that this is due to insufficient analysis, or to the lack of cross-linguistic study of phonological traces of phase boundaries: it is hard to imagine a language where word-initial consonants are strong, and first vowels of the word stable, but only in words that happen to be *vP*-initial (or *TP*-initial etc.). Also, we have seen a language, Corsican, where there is definitely no phonological trace of the spell-out of chunk sizes that range between the word and the utterance: (at least) *vP* will be a phase in Corsican as well, but its spell-out does not leave any phonological trace.

All this, however, does not really come as a surprise: we know that procedural sandhi-killers are process-specific (see section 3.1): should the *PIC* be responsible for blocking word-stress computation across word boundaries in English, it applies à la carte to stress, but not to flapping. The discussion of the behaviour of the initial CV leads to the same conclusion: chunks (i.e. phases) are determined in morpho-syntax and exist independently of whether they are “mobilized” in phonology, i.e. of whether they leave a phonological trace or not. Phonological traces are either produced by making a (specific) phonologi-

cal computation subject to the *PIC* at a specific chunk size, or by inserting a CV unit at the left edge of a phase. That is, phase boundaries may, but do not need to be accompanied by phonological effects.

Given our current understanding of syntactic phase structure and the (incomplete) inventory of chunk sizes that produce phonological traces, the only good match between “syntactic” and “phonological” phases is the *CP*, which corresponds to what is called the utterance above. The other chunk size that produces phonological effects (and massively so), the word, is not anything that is known to be a syntactic phase.

Table (18) below recapitulates the bumpy match between syntactic phases and chunk sizes that produce phonological effects.

(18) bumpy match between syntactic and phonological evidence for phases

phases (syntactic evidence)	phases (phonological evidence)	
CP	utterance	good match
vP	–	no phonological trace
TP	–	no phonological trace
DP	–	no phonological trace
...	–	no phonological trace
–	word	no syntactic trace

The bottom line is thus that somewhere a decision is made regarding the distribution of the initial CV over phases: this phase gets one, but that phase does not. A subset of the match between phases and initial CVs may be universal: some phases, say, *TP* (if the phasehood of this node is confirmed) may be disqualified altogether for carrying the initial CV. This may account for the lack of phonological response for most of the lines under (18).

In any event, though, there must be some space for parameterisation since we know that the word may or may not be elected as a CV-carrying phase (connected speech is the result of its non-election).

7. General conclusion

This article has proposed a number of criteria that allow us to determine whether the “barriers” that prevent processes from applying across word boundaries are of representational or procedural nature. The diagnostics are established on the grounds of assumptions regarding representational and procedural interface management: on the latter side, current syntactic phase theory, i.e. including *Phase Impenetrability*, is assumed; on the former, *CVCV* in gen-

eral and Lowenstamm’s (1999) initial CV in particular are the basis of the discussion. Developing some tenets of *Direct Interface* (Scheer, 2008, forthcoming a), it is argued that the insertion of CV units into the linear string at morpheme/word boundaries is the only way for morpho-syntax to bear on phonology by representational means.

Given these premises, process-specific sandhi-blocking, a hard fact of sandhi phonology, cannot be due to representational intervention: it must be a consequence of a *PIC* condition, which may or may not be associated to individual phonological processes. That is, it is important and useful to know what the phase structure in a language looks like, but this does not tell us anything about its phonological consequences: phases may or may not enforce *Phase Impenetrability*.

The same generalisation holds on the representational side. Parametric variation is studied regarding the question what the initial CV can be initial of. Two cases are identified: the initial CV heads words in some languages, utterances in others. In the former case it acts as a sandhi-blocker, while phonology freely applies across word boundaries in the latter. Or rather, to be precise, external sandhi supposes the absence of *both* sandhi blockers, representational and procedural: in order for phonology to apply across word boundaries, no *PIC* must be associated to the chunk that is defined by the boundary in question, and no CV unit must stand in the way.

Given that the initial CV always heads computational domains, it turns out to be phase-initial in all cases. Its distribution, though, is just like the distribution of the *PIC*: phases may or may not be headed by CV units on a language-specific basis. That is, the absence of the initial CV in word-initial position in Corsican does not mean that words are not phases in this language. It just means that Corsican does not distribute a CV unit with this phase. Or, in other words, units that the initial CV can be initial of are only phases, but not every phase is headed by an initial CV.

In sum, the skeleton of cross-word phonology is phase structure: every phase boundary may or may not be armed with a *PIC* and an initial CV – this is what parametric variation is made of in the communication of morpho-syntax with phonology.

This perspective is interesting in the context of the challenge that is raised against phase theory from the evidence for asymmetric spell-out, i.e. the independent access of *LF* and *PF*. A basic (if often tacit) assumption of phase theory is that *LF* and *PF* phases are always concomitant: when a given node is spelled out, its content is sent to and interpreted at both *LF* and *PF*. It is obvious that phase theory would be significantly weakened if it turned out that a given node could be independently spelled out at *LF* and *PF*. Chomsky (2004) is explicit on this.

- (19) Assume that all three components are cyclic. $[\bar{a}]$ In the worst case, the three cycles are independent; the best case is that there is a single cycle only. Assume that to be true. Then Φ [the phonological component] and Σ [the semantic component] apply to units constructed by NS [narrow syntax], and the three components of the derivation of $\langle \text{PHON}, \text{SEM} \rangle$ proceed cyclically in parallel. L [language] contains operations that transfer each unit to Φ and Σ . In the best case, these apply at the same stage of the cycle. [...] In this conception there is no LF: rather, the computation maps LA [lexical array] to $\langle \text{PHON}, \text{SEM} \rangle$ piece-by-piece cyclically (Chomsky, 2004: 107).

Responding to empirical pressure from various sides, though, independent LF and PF spell-out is proposed or considered by, among others, Marušič (2005), Marušič and Žaucer (2006), Felser (2004), Matushansky (2005), den Dikken (2007), Megerdooomian (2003) and Caha and Scheer (2008).

There is no doubt that simultaneous phases are to be preferred. The question is whether they resist empirical pressure. The parametric scenario that is argued for in this article may be a way to have our cake and eat it too, if at the expense of shrunk predictiveness: the phase structure of a sentence is uniquely defined at the morpho-syntactic level. Every time a phase head is hit upon spell-out its content is sent to both LF and PF. Every phase is thus processed by both interpretational modules, but this does not mean that an effect is systematically encountered: there are “free rides”. At least for PF, a phonological footprint of a phase is only left behind if either a PIC condition or a CV unit is associated to a phase. Whether this is the case or not is a matter of a parametric choice: the article has argued that (possible universal restrictions such as the impossibility of certain phases such as TP to be headed by a CV unit notwithstanding) there is an individual choice that is made for every phase which determines whether or not a PIC condition is associated to this particular phase, and whether or not it is headed by a CV unit.

This opens the possibility to reconcile symmetric spell-out with empirically observed PF-specific and LF-specific traces thereof, as well as with the fact that within PF (and probably LF) all phases do not leave footprints: PF-effects of phases are not an automatic consequence of phasehood; rather, they are the result of a selective association of a PIC condition and/or a CV unit to an individual phase. In other words, all phases are treated in the same way by morpho-syntax, but not by PF and LF.

References

- AELBRECHT, L. (2008), *Licensing ellipsis as Agree*, paper presented at the 27th West Coast Conference on Formal Linguistics, UCLA 16-18 May.
- BALOGNÉ-BÉRCES, K. (2004), *Connected speech phenomena in Strict CV phonology*, in «The Even Yearbook», 6, pp. 1-10.
- BALOGNÉ-BÉRCES, K. (2005), *Strict CV Phonology and the English Cross-Word Puzzle*, Ph.D thesis, Eötvös Loránd University, Budapest.
- BALTIN, M. (2007), *Deletion versus Pro-forms: a false dichotomy?* Ms., New York University.
- BENDJABALLAH, S. (2001), *The negative preterite in Kabyle Berber*, in «Folia Linguistica», 34, pp. 185-223.
- BENDJABALLAH, S. and HAIDEN, M. (2003a), *Templatic Architecture*, in «Recherches Linguistiques de Vincennes», 32, pp. 157-168.
- BENDJABALLAH, S. and HAIDEN, M. (2003b), *Meaningful vowels*, in BOTTARI, P. (2003, ed.), *Proceedings of the XXVIII Incontro di Grammatica Generativa*, Congedo Editore, Lecce.
- BERMUDEZ-OTERO, R. (forthcoming), *Stratal Optimality Theory*, Oxford University Press, Oxford.
- BOŠKOVIĆ, Ž. (2007), *Agree, Phases, and Intervention Effects*, in «Linguistic Analysis», 33, pp. 54-96.
- CAHA, P. and SCHEER, T. (2008), *The Syntax and Phonology of Czech Templatic Morphology*, in ANTONKO, A., BAILYN, J. and BETHIN, C. (2008, eds.), *Annual Workshop on Formal Approaches to Slavic Linguistics. The Stony Brook Meeting 2007*, Michigan Slavic Publications, Ann Arbor, pp. 68-83.
- CHOMSKY, N. (2000), *Minimalist inquiries: the framework*, in MARTIN, R., MICHAELS, D. and URIAGEREKA, J. (2000, eds.), *Step by Step. Essays on Minimalist Syntax in Honor of Howard Lasnik*, MIT Press, Cambridge, Mass., pp. 89-155.
- CHOMSKY, N. (2001), *Derivation by Phase*, in KENSTOWICZ, M. (2001, ed.), *Ken Hale: A Life in Language*, MIT Press, Cambridge, Mass., pp. 1-52.
- CHOMSKY, N. (2004), *Beyond explanatory adequacy*, in BELLETTI, A. (2004, ed.), *Structures and Beyond. The cartography of syntactic structures*, Vol. 3, Oxford University Press, Oxford, pp. 104-131.
- CHOMSKY, N. (2005), *Three factors in language design*, in «Linguistic Inquiry», 36, pp. 1-22.
- CHOMSKY, N., HALLE, M. and LUKOFF, F. (1956), *On Accent and Juncture in English*, in HALLE, M., LUNT, H., MCLEAN, H. and VAN SCHOONEVELD, C. (1956, eds.), *For Roman Jakobson. Essays on the occasion of his sixtieth birthday*, Mouton, The Hague, pp. 65-80.

- CONTINI, M. (1986), *Les phénomènes de sandhi dans le domaine sarde*, in ANDERSEN, H. (1986, ed.), *Sandhi Phenomena in the Languages of Europe*, Mouton de Gruyter, Berlin, pp. 519-550.
- CYRAN, E. (2003), *Complexity Scales and Licensing Strength in Phonology*, KUL, Lublin.
- DALBERA-STEFANAGGI, M.-J. (1977), *La lénition consonantique dans le parler corse de Vero et ses incidences sur l'analyse phonématique*, in «Annales de la Faculté des Lettres et Sciences Humaines de Nice», 28, pp. 47-60.
- DALBERA-STEFANAGGI, M.-J. (1981), *Sur la genèse et le fonctionnement de la mutation consonantique en corse*, in «Travaux du Cercle de Linguistique de Nice», 3, pp. 3-24. Reprinted in DALBERA-STEFANAGGI, M.-J. (2001), *Essais de linguistique corse*, Piazzola, Ajaccio, pp. 61-75.
- DALBERA-STEFANAGGI, M.-J. (1991), *Les corrélations de sonantes en corse*, in KREMER, D. (1991, ed.), *Actes du 18e Congrès International de Linguistique et de Philologie Romanes*, Vol 3, Niemeyer, Tübingen, pp. 496-507.
- DALBERA-STEFANAGGI, M.-J. (2001a), *La Corse au regard de la lénition consonantique: aires, strates, systèmes*, Piazzola, Ajaccio.
- DALBERA-STEFANAGGI, M.-J. (2001b), *Essais de linguistique corse*, Piazzola, Ajaccio.
- DALBERA, J.-P. and DALBERA-STEFANAGGI, M.-J. (2004), *Grands corpus dialectaux ou la phonologie indiscrète*, in «Corpus», 3, pp. 399-433.
- DEN DIKKEN, M. (2007), *Phase Extension: Contours of a theory of the role of head movement in phrasal extraction*, in «Theoretical Linguistics», 33, pp. 1-41.
- ENCREVÉ, P. (1988), *La liaison avec et sans enchaînement: phonologie tridimensionnelle et usages du français*, Seuil, Paris.
- EPSTEIN, S., GROAT, E.M., KAWASHIMA, R. and KITAHARA, H. (1998), *A Derivational Approach to Syntactic Relations*, OUP, Oxford.
- EPSTEIN, S. and SEELY, D.T. (2002), *Rule Applications as Cycles in Level-Free Syntax*, in EPSTEIN, S. and SEELY, D.T. (2002, eds.), *Derivation and Explanation in the Minimalist Program*, Blackwell, Oxford, pp. 65-89.
- EPSTEIN, S. and SEELY, D. T. (2006), *Derivation in Minimalism*, CUP, Cambridge.
- FELSER, C. (2004), *Wh-copying, phases, and successive cyclicity*, in «Lingua», 114, pp. 543-574.
- GIANNELLI, L. and SAVOIA, L. (1978), *L'indebolimento consonantico in Toscana (I)*, in «Rivista Italiana di Dialettologia», 2, pp. 25-58.
- GUERSSEL, M. and LOWENSTAMM, J. (1990), *The derivational morphology of the Classical Arabic Verb*, Ms. Université Paris 7 & UQAM.
- HALE, K. (1973), *Deep-surface canonical disparities in relation to analysis and change: an Australian case*, in SEBOEK, T.A. (1973, ed.), *Diachronic, areal, and typological linguistics*, Mouton, The Hague, pp. 401-458.

- HALLE, M. and MOHANAN, K. (1985), *Segmental Phonology of Modern English*, in «Linguistic Inquiry», 16, pp. 57-116.
- HALLE, M. and VERGNAUD, J.-R. (1987), *An Essay on Stress*, MIT Press, Cambridge, Mass.
- HINTERHÖLZL, R. (2006), *The Phase Condition and cyclic Spell-out: Evidence from VP-topicalization*, in FRASCARELLI, M. (2006, ed.), *Phases of Interpretation*, de Gruyter, Berlin, pp. 237-259.
- INKELAS, S. (1990), *Prosodic Constituency in the Lexicon*, Garland, New York.
- KAHN, D. (1976), *Syllable-based generalizations in English phonology*, Ph.D dissertation, MIT. Published as KAHN, D. (1980), Garland Press, New York.
- KAYE, J. (1992), *On the interaction of theories of Lexical Phonology and theories of phonological phenomena*, in DRESSLER, U., LUSCHÜTZKY, H., PFEIFFER, O. and RENNISON, J. (1992, eds.), *Phonologica 1988*, Cambridge University Press, Cambridge, pp. 141-155.
- KAYE, J. (1995), *Derivations and Interfaces*, in DURAND, J. and KATAMBA, F. (1995, eds.), *Frontiers of Phonology*, Longman, London-New York, pp. 289-332. Also in «SOAS Working Papers in Linguistics and Phonetics», 3, 1993, pp. 90-126.
- KIPARSKY, P. (1982a), *Lexical morphology and phonology*, in YANG, I.S. (1982, ed.), *Linguistics in the morning calm*, Hanshin, Seoul, pp. 3-91.
- KIPARSKY, P. (1993), *Blocking in nonderived environments*, in HARGUS, S. and KAISSE, E. (1993, eds.), *Studies in Lexical Phonology*, Academic Press, San Diego, pp. 277-313.
- KIPARSKY, P. (1982b), *From Cyclic Phonology to Lexical Phonology*, in VAN DER HULST, H. and SMITH, N. (1982, eds.), *The structure of phonological representations I*, Foris, Dordrecht, pp. 131-175.
- KIPARSKY, P. (2000), *Opacity and cyclicity*, in «The Linguistic Review», 17, pp. 351-365.
- LAHROUCHI, M. (2001), *Aspects morpho-phonologiques de la dérivation verbale en berbère (parler chleuh d'Agadir)*, Ph.D dissertation, Université Paris 7.
- LIBERMAN, M. and PRINCE, A. (1977), *On Stress and Linguistic Rhythm*, in «Linguistic Inquiry», 8, pp. 249-336.
- LOWENSTAMM, J. (1996), *CV as the only syllable type. Current trends in Phonology*, in DURAND, J. and LAKS, B. (1996, eds.), *Models and Methods*, ESRI, Salford, Manchester, pp. 419-441.
- LOWENSTAMM, J. (1999), *The beginning of the word*, in RENNISON, J. and KÜHNHAMMER, K. (1999, eds.), *Phonologica 1996*, Holland Academic Graphics, La Hague, pp. 153-166.

- MAROTTA, G. (2000-2001), *Non solo spiranti. La gorgia toscana nel parlato di Pisa*, in «L'Italia Dialettale», 62, pp. 27-60.
- MAROTTA, G. (2008), *Lenition in Tuscan Italian (Gorgia Toscana)*, in DE CARVALHO, J.B., SCHEER, T. and SÉGÉRAL, P. (2008, eds.), *Lenition and Fortition*, de Gruyter, Berlin, pp. 235-271.
- MARUŠIČ, F. (2005), *On non-simultaneous phases*, Ph.D. dissertation, SUNY, Stony Brook.
- MARUŠIČ, F. and ŽAUCER, R. (2006), *On the intensional feel-like construction in Slovenian*, in «Natural Language and Linguistic Theory», 24, pp. 1093-1159.
- MARVIN, T. (2002), *Topics in the Stress and Syntax of Words*, Ph.D dissertation, MIT.
- MASCARÓ, J. (1976), *Catalan Phonology and the Phonological Cycle*, Ph.D. dissertation, MIT.
- MATUSHANSKY, O. (2005), *Going through a phase*, in «MIT Working Papers in Linguistics», 49, pp. 157-181.
- MEGERDOOMIAN, K. (2003), *Asymmetries in Form and Meaning: Surface Realization and the Interface Conditions*, Paper presented at Approaching Asymmetry at the Interfaces, UQAM, Montreal.
- MOHANAN, K. and MOHANAN, T. (1984), *Lexical Phonology of the consonant system in Malayalam*, in «Linguistic Inquiry», 15, pp. 575-602.
- NESPOR, M. and VOGEL, I. (1986), *Prosodic Phonology*, Foris, Dordrecht.
- NEWELL, H. and SCHEER, T. (2007), *Procedural First*, Paper presented at the 38th Poznań Linguistic Meeting, Poznań 13-16 September.
- NIEDERMANN, M. (1985), *Précis de phonétique historique du latin*, Klincksieck, Paris.
- PAGLIANO, C. (2003), *L'épenthèse consonantique en français. Ce que la syntaxe, la sémantique et la morphologie peuvent faire à la phonologie*, Ph.D dissertation, Université de Nice.
- PRINCE, A. and SMOLENSKY, P. (1993), *Optimality Theory. Constraint Interaction in Generative Grammar*, Ms, Rutgers University, University of Colorado (ROA version August 2002).
- RUBACH, J. (1984), *Cyclic and Lexical Phonology: The Structure of Polish*, Foris, Dordrecht.
- RUBACH, J. (1997), *Extrasyllabic consonants in Polish: Derivational Optimality Theory*, in ROCA, I. (1997, ed.), *Derivations and Constraints in Phonology*, Clarendon, Oxford, pp. 551-581.
- RUBACH, J. and BOOIJ, G. (1984), *Morphological and prosodic domains in Lexical Phonology*, in «Phonology Yearbook», 1, pp. 1-27.

- SCHEER, T. (2004), *A Lateral Theory of Phonology, Vol.1, What is CVCV, and why should it be?*, Mouton de Gruyter, Berlin.
- SCHEER, T. (2008), *Why the Prosodic Hierarchy is a diacritic and why the Interface must be Direct*, in HARTMANN, J., HEGEDŰS, V. and VAN RIEMSDIJK, H. (2008, eds.), *Sounds of Silence: Empty Elements in Syntax and Phonology*, Elsevier, Amsterdam, pp. 145-192.
- SCHEER, T. (2009), *Intermodular Argumentation and the Word-Spell-Out-Mystery*, in GROHMANN, K. (2009, ed.), *Explorations of Phase Theory: Interpretation at the Interfaces*, Mouton de Gruyter, Berlin, pp. 23-65.
- SCHEER, T. (forthcoming a), *How morpho-syntax talks to phonology. A survey of extraphonological information in phonology since Trubetzkoy's Grenzsignale*, Mouton de Gruyter, Berlin.
- SCHEER, T. (forthcoming b), *Intermodular argumentation: morpheme-specific phonologies are out of business in a phase-based architecture*, in SHIR, N. and ROCHMAN, L. (eds.), *The Sound Pattern of Syntax*, OUP, Oxford.
- SÉGÉRAL, P. and SCHEER, T. (2001a), *La Coda-Miroir*, in «Bulletin de la Société de Linguistique de Paris», 96, pp. 107-152.
- SÉGÉRAL, P. and SCHEER, T. (2001b), *Les séquences consonne + yod en gallo-roman*, in «Recherches Linguistiques de Vincennes», 30, pp. 87-120.
- SÉGÉRAL, P. and SCHEER, T. (2005), *What lenition and fortition tells us about Gallo-Romance Muta cum Liquida*, in GEERTS, T., VAN GINNEKEN, I. and JACOBS, H. (2005, eds.), *Romance Languages and Linguistic Theory 2003*, Benjamins, Amsterdam, pp. 235-267.
- SÉGÉRAL, P. and SCHEER, T. (2008), *The Coda Mirror, stress and positional parameters*, in DE CARVALHO, J.B., SCHEER, T. and SÉGÉRAL, P. (2008, eds.), *Lenition and Fortition*, Mouton de Gruyter, Berlin, pp. 483-518.
- SEIGNEUR-FROLI, D. (2003), *Diachronic consonant lenition & exotic word-initial clusters in Greek: a unified account*, in STAVROU-SIFAKI, M. and FLIATOURAS, A. (2003, eds.), *Studies in Greek Linguistics. Proceedings of the 23rd annual meeting of the department of linguistics*, University of Thessaloniki, Thessaloniki, pp. 345-357.
- SEIGNEUR-FROLI, D. (2006), *Le Statut phonologique du début de mot grec. Lénitions consonantiques et libertés phonotactiques initiales dans la diachronie de la langue commune et dans le dialecte de Lesbos*, Ph.D dissertation, University of Nice.
- SELKIRK, E. (1981 [1978]), *On prosodic structure and its relation to syntactic structure*, in FRETHERM, T. (1981, ed.), *Nordic Prosody II*, TAPIR, Trondheim, pp. 111-140.
- SELKIRK, E. (1984), *Phonology and Syntax: The Relation between Sound and Structure*, MIT Press, Cambridge, Mass.
- SELKIRK, E. (1986), *On derived domains in sentence phonology*, in «Phonology», 3, pp. 371-405.

- SZIGETVÁRI, P. (1999), *VC Phonology: a theory of consonant lenition and phonotactics*, Ph.D dissertation, Eötvös Loránd University Budapest.
- SZIGETVÁRI, P. AND SCHEER, T. (2005), *Unified representations for the syllable and stress*, in «Phonology», 22, pp. 37-75.
- VOGEL, I. (1991), *Level ordering in Italian Lexical Phonology?*, in BERTINETTO, P.M., KENSTOWICZ, M. and LOPORCARO, M. (1991, eds.), *Certamen Phonologicum II*, Sellier & Rosenberg, Torino, pp. 81-101.
- YIP, M. (1996), *Lexicon Optimization in languages without alternations*, in DURAND, J. and LAKS, B. (1996, eds.), *Current trends in Phonology. Models and Methods*, Vol. 2, ESRI, Salford, Manchester, pp. 759-790.

DIANA PASSINO

The allomorphy of *nən* as a case of vowel/zero alternation
in Teraman Abruzzese*

1. Introduction

This contribution investigates a characteristic of Eastern Abruzzese dialects that has not been noticed in previous studies (Savini, 1881, Giammarco, 1960, 1979, Avolio, 1995, Bigalke, 1996, Hastings, 1997, 2001): the allomorphy of the negative adverb *nən*¹ that, in Teraman and other Eastern Abruzzese dialects, may surface as [nən], [n:] and [nə]. The map in Table 1, taken from Giammarco (1979: 88), shows the Italian region of Abruzzi and the area where Eastern Abruzzese dialects (Abruzzese orientale o adriatico), namely Teraman, Pescaraese, Chietino, Lancianese and Vastese, are spoken.

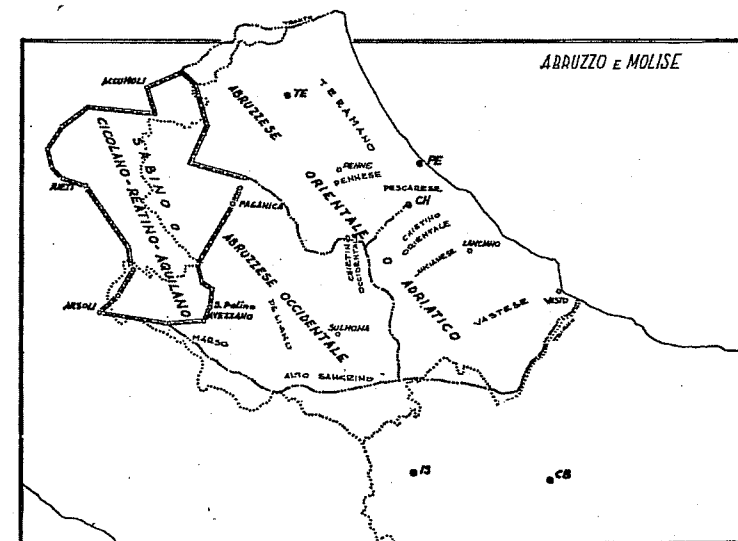

Table 1. From Giammarco (1979: 88)

* I am indebted to Laura Bafile, Tobias Scheer, Anna M. Thornton and two anonymous reviewers who have helped me to greatly improve both the form and the content of this contribution. All usual disclaimers apply.

¹ The negative adverb will be quoted by using the allomorph which occurs more frequently.

Ricevuto: marzo 2009
Accettato: luglio 2009

SSL XLVII (2009), pp. 83-110